



Wireless Metallic Earbuds

PBT575 User Manual



Questions?
Need some help?
This manual will help you
enjoy your new product



or visit us at:
www.southern telecom.com
Click on "Product Support"

Pairing the Earbuds

1. Long press the [⏻] button. A tone will be heard indicating the earbuds are powered ON and the LED indicator will flash **RED** and **BLUE**.
2. Set your mobile device to search for Bluetooth devices. When your mobile device finds the earbuds, select **PBT575** from the list of found devices.
3. Once successfully paired, a tone will be heard and the LED indicator will slowly flash **BLUE**.

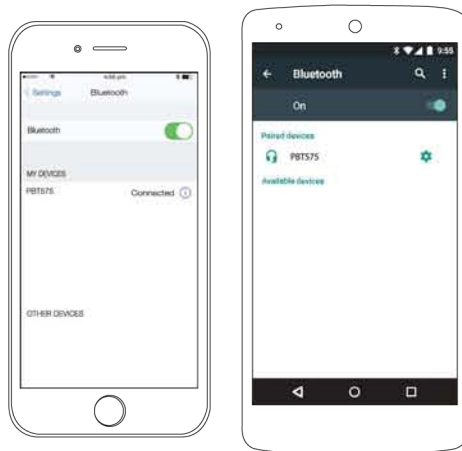

For iOS or Android

- Go to **SETTINGS > BLUETOOTH**
(Make sure Bluetooth is turned ON)



The screenshots above are typical of many Bluetooth-enabled devices in the market today and are used to assist in the explanation of the pairing process. Your Bluetooth-enabled device's interface and interaction with the earbuds may differ slightly from the illustrations above.

In the Box

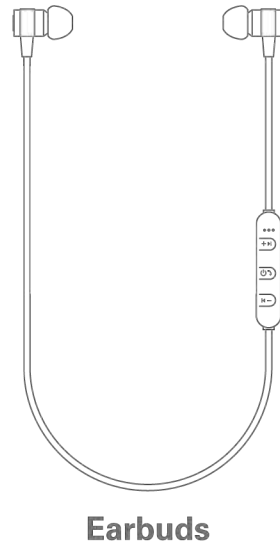

Earbuds



Extra Small & Large Ear Tips

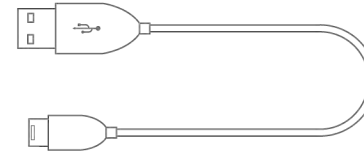

Micro USB Charging Cable

Using the Earbuds

Powering ON/OFF

- Turn the earbuds ON by long pressing the [⏻] button. A tone will indicate that the earbuds are powered ON.
- Turn the earbuds OFF by long pressing the [⏻] button. A tone will indicate that the earbuds are powered OFF.

NOTE: The earbuds will go into sleep mode after a period of inactivity. While in sleep mode, the LED indicator will flash **BLUE** intermittently. To wake the device press the [⏻] button.

Answering Phone Calls

- To answer a phone call quick press the [⏻] button.
- To hang up, quick press the [⏻] button. Music playback will automatically resume.

Location of Controls

(Front of Control Piece)

1. [⏻] Button:
Quick Press - Increase volume
Long Press - Skip to the next track
2. [⏻] Button:
Quick Press - Play/pause
Quick Press - Answer/end call
Long Press - Power ON/OFF
3. [⏻] Button:
Quick Press - Decrease volume
Long Press - Skip to previous track
4. LED Indicator

(Side of Control Piece)

5. Micro USB Charging Port

(Front)

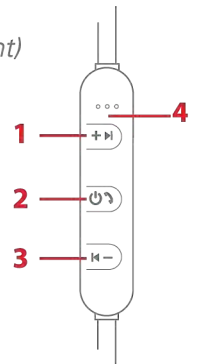

(Side)

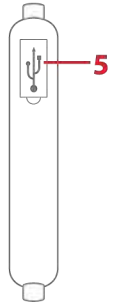

Using the Earbuds

Playing Music

To enjoy music wirelessly on your earbuds, make sure that they are properly paired to your Bluetooth-enabled device. If you are pairing the device for the first time, please consult the **Pairing the Earbuds** part of this user guide.

Playing/Pausing Music

- Quick press the [⏻] button to pause the music.
- Quick press the [⏻] button again to resume music playback.

Skipping Songs

- Long press the [⏻] button to go to the previous song.
- Long press the [⏻] button to go to the next song.

Adjusting the Volume

- Quick press the [⏻] to decrease the volume of music playback.
- Quick press the [⏻] to increase the volume of music playback.

Charging the Earbuds

To charge the earbuds, remove the plastic protective cover over the micro USB charging port and attach the small end of the supplied micro USB cable to the port on the side of the earbuds. Attach the large end to the USB port on a computer, USB charging device, or **5V USB adapter**.

The charging LED indicator will turn **RED** while charging and turn **OFF** when fully charged.

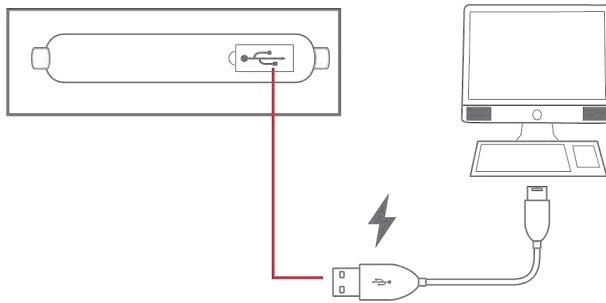

i Make sure you charge your earbuds for at least **2 - 3 hours** before using it for the first time.

Warranty Information

This product as supplied and distributed new by AIT, Inc. ("AIT") to the original consumer purchaser is warranted by AIT against defects in material and workmanship for a period of one year from your date of purchase ("Warranty"). In the unlikely event that this product is defective, or does not perform properly, you may within one year from your original date of purchase return it to the authorized service center for repair or exchange.

TO OBTAIN WARRANTY SERVICE:

- Go to our website portal to receive an SRO number.
- Provide proof of the date of purchase within the package (dated bill of sale).
- Prepay all shipping costs to the authorized service center, and remember to insure your return.
- Include a return shipping address (no P.O. Boxes), a telephone contact number, and the defective unit within the package.
- Describe the defect or reason you are returning the product.

Your product will be repaired or replaced, at our option, for the same or similar model of equal value if examination by the service center determines this product is defective. Products received damaged as a result of shipping, will require you to file a claim with the carrier.

The shipping address of the authorized service center is:

AIT, Inc.
Customer Service Dept. 36
c/o Southern Telecom
400 Kennedy Drive
Sayreville NJ 08872

For further customer service:
 www.southern telecom.com
Click on **Product Support**

IN NO EVENT WILL AIT, ITS MANUFACTURERS, DISTRIBUTORS OR PLR IP HOLDINGS, LLC BE LIABLE FOR ANY INCIDENTAL, DIRECT, INDIRECT, SPECIAL, PUNITIVE OR CONSEQUENTIAL DAMAGES (SUCH AS, BUT NOT LIMITED TO, DAMAGES FOR LOSS OF PROFITS, BUSINESS, SAVINGS, DATA OR RECORDS) RELATED TO THIS PRODUCT. EXCEPT AS STATED HEREIN, NO OTHER WARRANTIES SHALL APPLY.

Legal Information

READ THIS CAREFULLY AND SAVE FOR FUTURE REFERENCE

This equipment has been tested and found to comply with the limits for a Class B digital device, pursuant to part 15 of the FCC Rules. These limits are designed to provide reasonable protection against harmful interference in a residential installation. This equipment generates, uses and can radiate radio frequency energy and, if not installed and used in accordance with the instructions, may cause harmful interference to radio communications. However, there is no guarantee that interference will not occur in a particular installation. If this equipment does cause harmful interference to radio or television reception, which can be determined by turning the equipment off and on, the user is encouraged to try to correct the interference by one or more of the following measures:

- Reorient or relocate the receiving antenna.
- Increase the separation between the equipment and receiver.
- Connect the equipment into an outlet on a circuit different from that to which the receiver is connected.
- Consult the dealer or an experienced radio/TV technician for help.

Caution: Any changes or modifications to this device not explicitly approved by manufacturer could void your authority to operate this equipment.

This device complies with part 15 of the FCC Rules. Operation is subject to the following two conditions: (1) This device may not cause harmful interference, and (2) this device must accept any interference received, including interference that may cause undesired operation.

The device has been evaluated to meet general RF exposure requirement. The device can be used in portable exposure condition without restriction.

PLR IP Holdings, LLC, its licensees and affiliates, fully support all electronic waste initiatives. As responsible stewards of the environment, and to avoid violating established laws, you should properly dispose of this product in compliance with all applicable regulations, directives or other governances in the area where you reside. Please check with local authorities or the retailer where you purchased this product to determine a location where you can appropriately dispose of the product.

Polaroid, Polaroid & Pixel, Polaroid Color Spectrum, and Polaroid Classic Border Logo are trademarks of PLR, IP Holdings, LLC, used under license.

Legal Information (cont'd)

WARNING Li-ion Battery Inside

This product is fitted with a Li-ion battery. Do not damage, open, or dismantle the battery and do not use it in damp and/or corrosive conditions. Use only with compatible chargers. Never dispose of batteries in a fire, and never expose them to high temperatures. Do not expose the product to temperatures exceeding 60°C (140°F).



The crossed-out garbage bin symbol means that you must not dispose of this product together with unsorted household waste.

Rain/Moisture Warning

- Do not expose the unit to extreme temperatures (heat or cold), open flames, humid conditions, or wet conditions.
- Do not submerge in water.
- Do not open this product or attempt to repair the unit yourself should it not be working.



 Instantly recognizable. Instantly reassuring. The Polaroid Classic Border and Polaroid Color Spectrum logos let you know you've purchased a product that exemplifies the best qualities of our brand and that contribute to our rich heritage of quality and innovation.